



**Power Cord Access**



**Key Lock**



**Gas Struts**

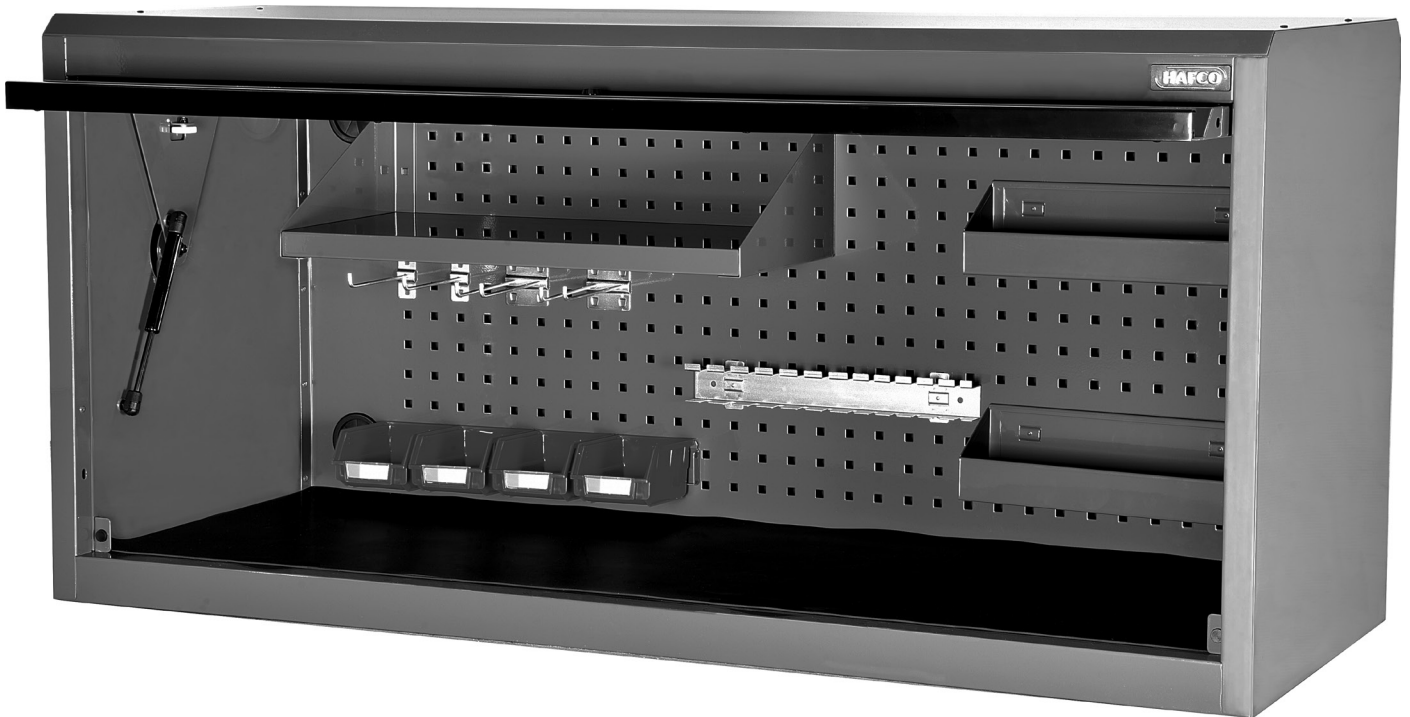

Edition : 1.0  
Date: (05/26)

# Instruction Manual

## PROFESSIONAL SERIES TOP HUTCH TPS-56H

Order Code: (T6881)



## PROFESSIONAL SERIES

### BEFORE ASSEMBLING

Please read this instruction manual before assembly.



#### CAUTION

Before assembly please pay attention to the following points in priority;

**Confirmation of components:** Before assembling, please confirm all parts arrived and are in good order.

**Site for assembly:** Please assemble it on the soft floor such as smooth carpet and flannel blanket. When you assemble on wooden floor, please put thin towels on the floor.

**Points for attention when assembling:** Please wear gloves to ensure that it can be assembled safely, and use two persons to help in the assembly process.

### SAFETY INFORMATION

1. Persons other than professionals should not disassemble, repair or modify the product.
2. Keep children, infants and pregnant women away from installation places.
3. Center securely within lip on top of roller cabinet.
4. Place on top of matching roller cabinet only.
5. Do not lift while loaded.
6. Do not place objects on top or hang objects off side.
7. Evenly distribute load from bottom up. Uneven loading causes tipping. Be aware of dynamic loading! Sudden movement may briefly create excess load causing tipping.
8. Do not overload and make sure lid is closed and locked when moving.
9. Do not perform welding, hammering or disassembly work on top plate.



**CAUTION:** Do not stand on this product. You may fall which may cause personal injury or product damage.



**CAUTION:** Keep the product on level surfaces. The product may become unstable and tip if stored or moved on an un-level surface, which may cause personal injury or product damage.



**CAUTION:** Place top hutch inside inner lip on top of roller cabinet. Make sure tool chest sits flush on roller cabinet. Only use matching roller cabinet.



**CAUTION:** Lock the hutch lid before moving this product. If Hutch lid become open it may make the product unstable and tip, which may cause personal or product damage.



**CAUTION:** Do not lift while loaded. Have assistant help place on roller cabinet while using the correct mechanical lifting aids.



### SPECIFICATIONS

Overall size: 1420 x 546 x 674 (WxDxH)

Package size: 1490 x 610 x 840 (WxDxH)

Nett Weight: 65.2kg

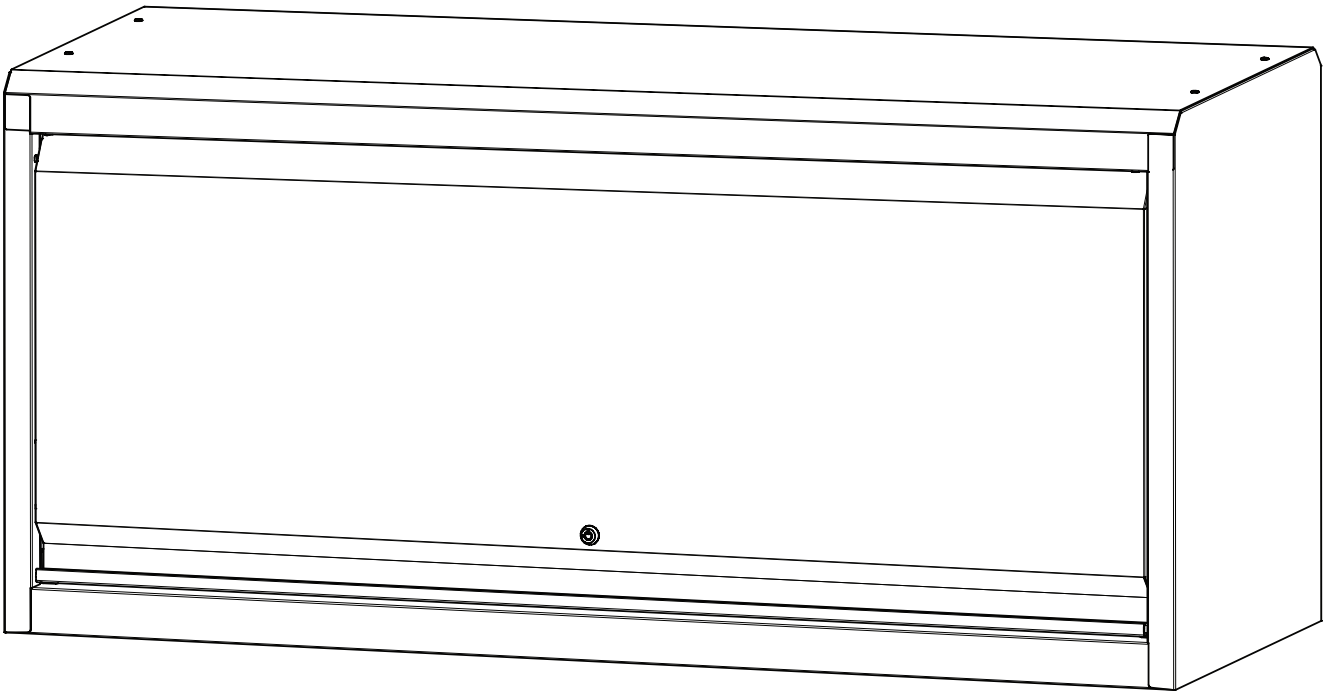

Keys (x4)



Gas Struts (x2)

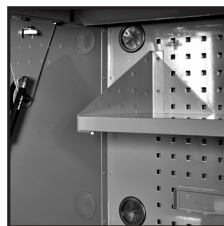

Cable Access Points (x4)

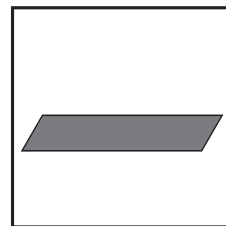

Rubber Liner (x1)

### INCLUDES

- 1 x Shelf (600 x 280 x 180mm)
- 1 x 12-piece Screwdriver Holder (370mm wide)
- 2 x Can Holders (330 x 100 x 100mm)
- 1 x Plastic Bucket Holder Bracket (440mm wide)
- 4 x Plastic Buckets (125 x 90 x 67mm)
- 10 x 150mm Single Prong Hooks
- 10 x 150mm Double Prong Hooks

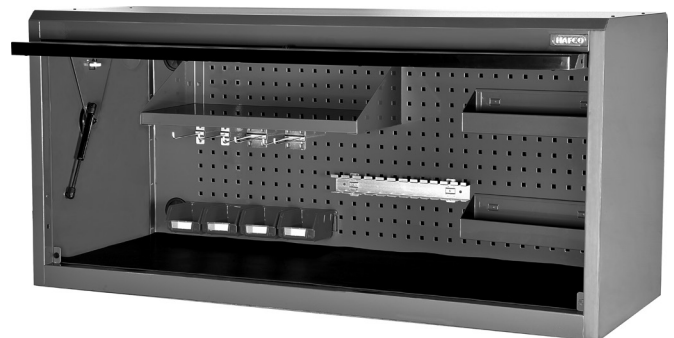

# TOP HUTCH

## PROFESSIONAL SERIES



### UNPACKING INSTRUCTIONS

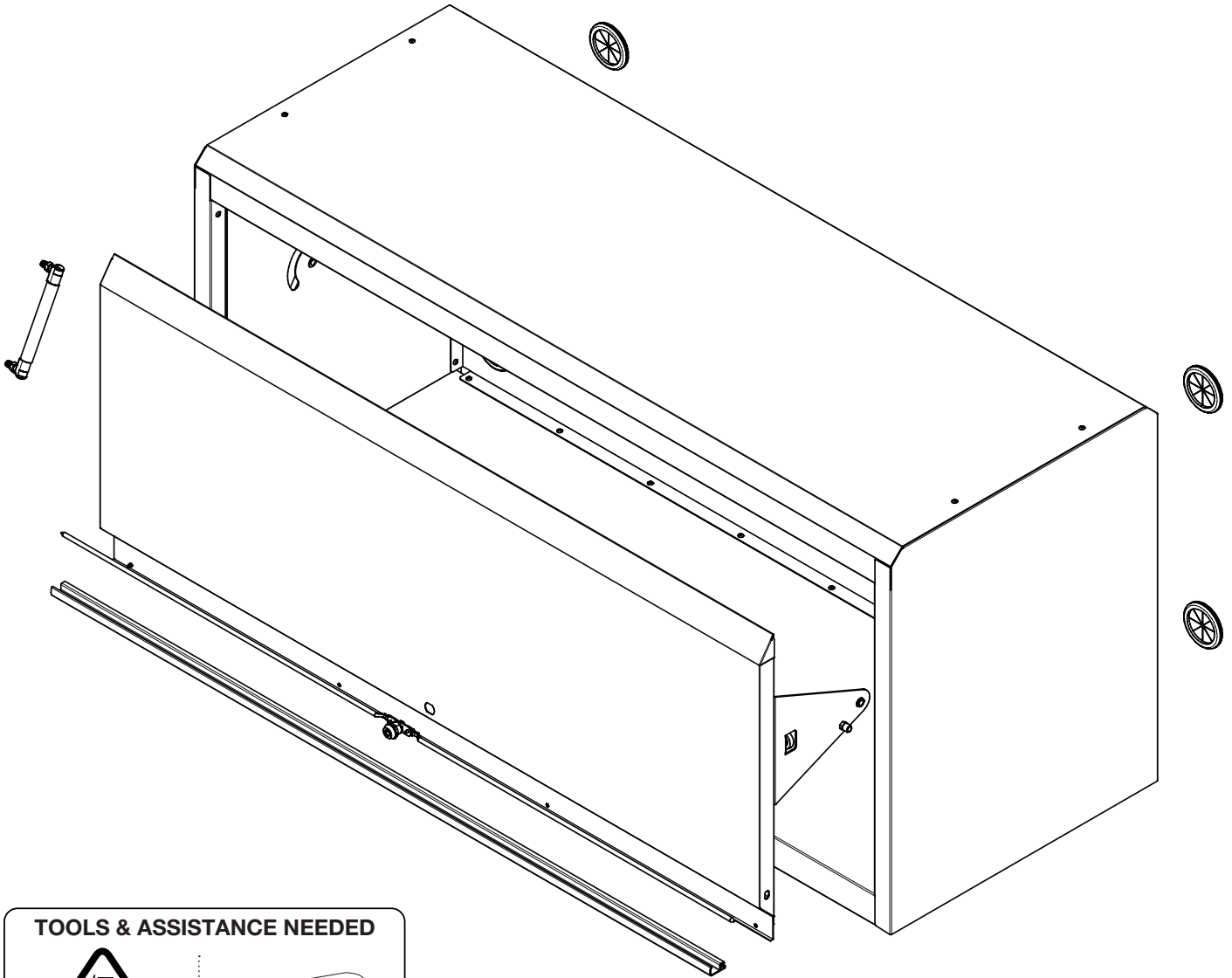

**TOOLS & ASSISTANCE NEEDED**



Utility Knife

\*Tools not included



#### 1. Unbox the Top Hutch:

Use a knife to carefully open the carton and remove the top hutch. Be cautious to avoid damaging the contents.

#### 2. Unlock and Prepare:

- Using the supplied keys, unlock the top hutch.
- Ensure the foam liner is correctly positioned inside the hutch.
- Fit the shelf, can holders, bucket holder, prongs and screwdriver holder onto the pegboard in your preferred layout.
- Arrange accessories as required and prepare the unit for use.

### MOUNTING TOP HUTCH ONTO ROLLER CABINET

#### 1. Close & Lock Drawers and Hutch

- Ensure all roller cabinet drawers are fully closed and the top hutch door is fully shut.
- Using the supplied key, lock both the roller cabinet and top hutch before installation. (Fig. 1)

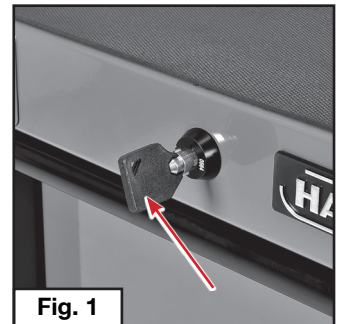

#### 2. Secure the Roller Cabinet

- Position the roller cabinet on a level surface.
- Lock both brake wheels to prevent movement during installation. (Fig. 2)

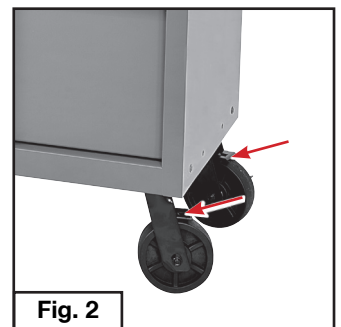

#### 3. Lift Top Hutch into Position

- Using two persons or suitable lifting equipment, carefully lift the top hutch onto the roller cabinet.
- Ensure the top hutch sits flush inside the steel locating lip of the roller cabinet. (Fig. 3)

#### 4. Ready for use

- Unlock all drawers and doors before use.

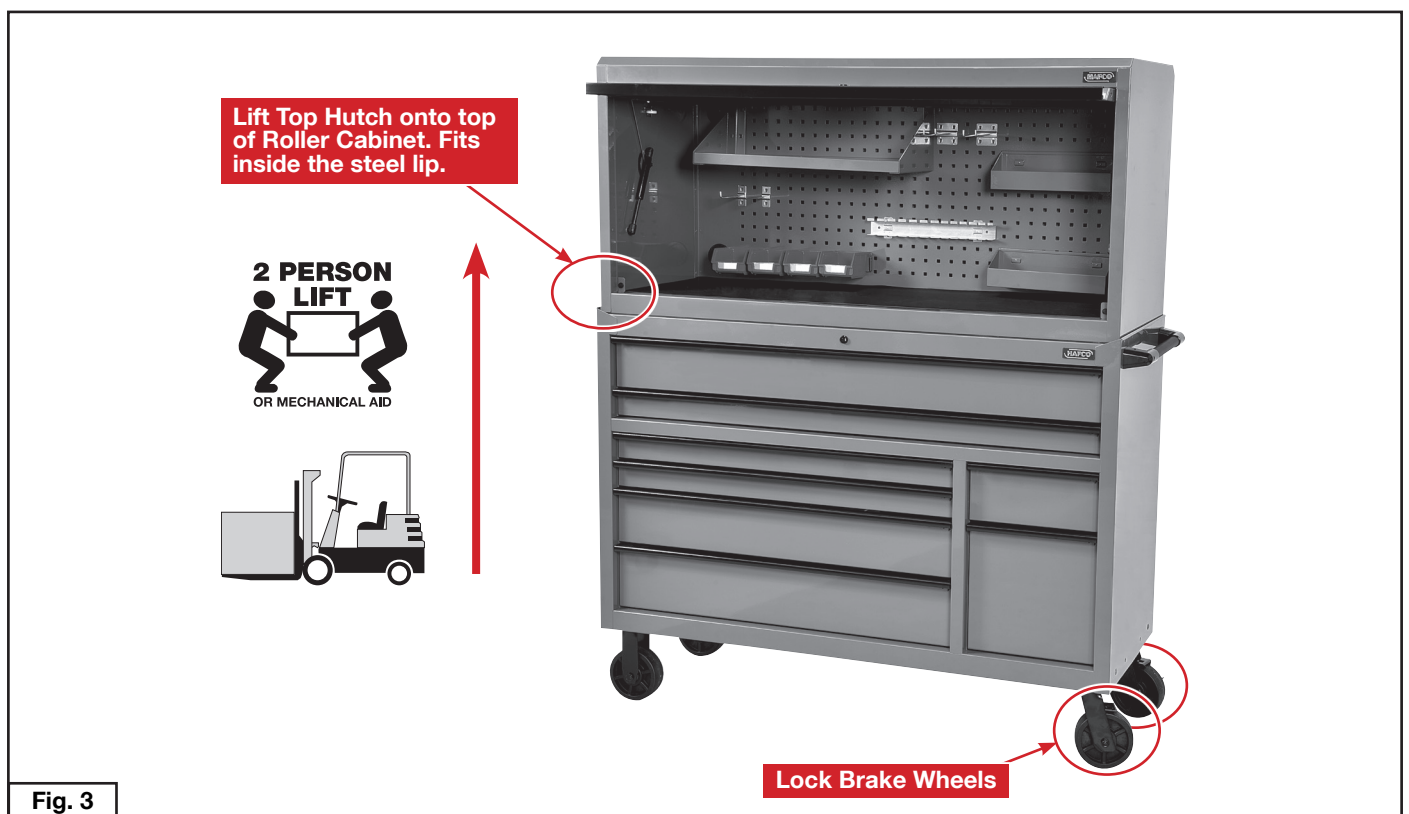



### **ENVIRONMENT PROTECTION**

Recycle unwanted materials instead of disposing of them as waste. All tools, accessories and packaging should be sorted, taken to a recycling centre and disposed of in a manner which is compatible with the environment. When the product becomes completely unserviceable and requires disposal, drain any fluids (if applicable) into approved containers and dispose of the product and fluids according to local regulations.

Imported by

---

**HARE & FORBES**  
**MACHINERYHOUSE**

**Australian Distributor**

Hare & Forbes  
Machineryhouse  
Sydney - Melbourne  
Adelaide - Brisbane - Perth

Ph: 1300 202 200  
[www.machineryhouse.com.au](http://www.machineryhouse.com.au)

**MACHINERYHOUSE**

**New Zealand Distributor**

Machineryhouse  
Auckland  
Christchurch

Ph: 0800 142 326  
[www.machineryhouse.co.nz](http://www.machineryhouse.co.nz)